

ITT

Residential Water Systems

Goulds Pumps

JRS Shallow Well Jet Pumps 1/2, 3/4 and 1 HP (60 Hz)

JRS5, JRS5H, JRS7 and JRS10

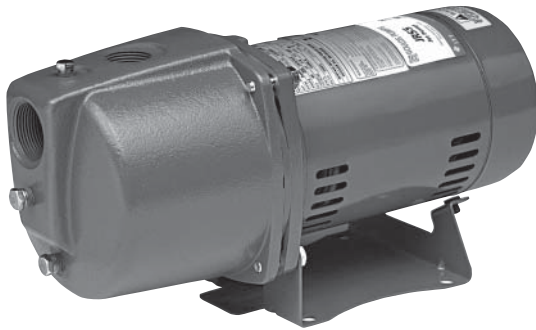

FEATURES

- **Compact:** Design has an integral shallow well jet built into the casing, which eliminates the need for a separate shallow well adapter.
- **Serviceable:**
 - Back pullout design allows disassembly of pump for service without disturbing piping.
 - Two compartment motor for easy access to motor wiring and replaceable components.
 - Nozzle clean out plug in pump casing.
 - Corrosion resistant, engineered plastic tubing and fittings are easily removed for cleaning. Premium O-ring design fittings need only be hand tight to seal.
 - O-ring casing seal.
- **Drain Plug:** For ease of winterizing and maintenance.
- **Seal Housing:** Engineered composite. Corrosion and abrasion resistant.
- **Impeller:** F.D.A. compliant, glass filled Noryl®. Corrosion and abrasion resistant.
- **Diffuser (Guidevane):** F.D.A. compliant, injection molded, food grade, glass filled Lexan® for durability and abrasion resistance.
- **Tubing and Fittings:** F.D.A. compliant engineered plastic is corrosion and U.V. resistant.
- **Powered for Continuous Operation:** Pump ratings are within the motor manufacturer's recommended working limits. Can be operated continuously without damage.
- **Corrosion Resistant:** Electro-coated paint process is applied inside and out, then baked on.
- **Excellent Air Handling Ability:** After initial priming the pump has the ability to reprime itself even when air gets into the system. Pumping resumes once the water level rises above the foot valve.

 **GOULDS PUMPS**

Goulds Pumps is a brand of ITT Corporation.

www.goulds.com

Engineered for life



ITT

GOULDS PUMPS Residential Water Systems

APPLICATIONS

Specifically designed for:

- Homes
- Cottages
- Booster service

SPECIFICATIONS

Pump:

- Pipe connections:
1 1/4" suction, 1" discharge.
- Pressure switch:
AS4FX preset (30-50 PSI).

Motor:

- NEMA service factors.
- 60 Hz.
- 1/2 – 1 HP, 115/230 V capacitor start.
- Single phase.

- 3500 RPM.
- Built-in overload with automatic reset.
- Stainless steel shaft.
- Rotation: clockwise when viewed from motor end.

Maximum temperature: 140°F.

SYSTEM COMPONENTS

■ **Basic Pump Unit:** Includes pump with integral shallow well jet (nozzle and venturi), motor, pressure switch and tubing.

AGENCY LISTINGS



Canadian Standards Association
LR38549

Goolds Pumps is ISO 9001 Registered.

COMPONENTS

Item No.	Description
1	Nozzle
2	Venturi
3	Cast iron casing
4	Separator plate
5	Diffuser (Guidevane)
6	Impeller
7	Mechanical seal
8	Motor
9	Pressure switch
10	Seal housing

DIMENSIONS AND WEIGHTS

Order No.	HP	(Inches)			Wt. (lbs.)
		Length	Width	Height	
JRS5(H)	1/2	16 13/16	8 3/4	8 1/4	30
JRS7	3/4	17 5/16	8 3/4	8 1/4	32
JRS10	1	18 3/16	8 3/4	8 1/4	34

(All dimensions are in inches and weights in lbs. Do not use for construction purposes.)

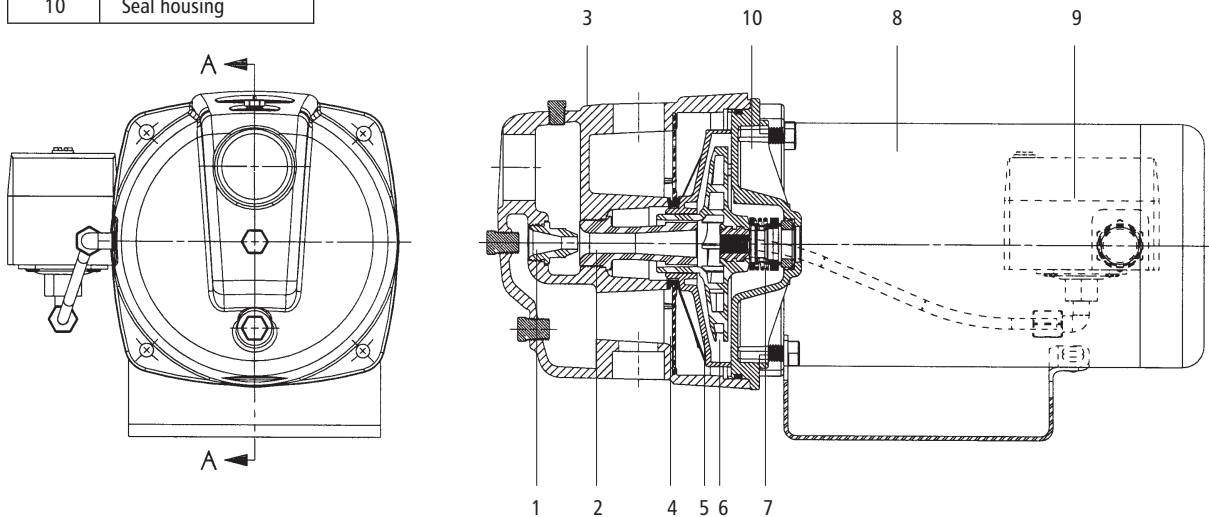



ITT

GOULDS PUMPS Residential Water Systems

PERFORMANCE RATINGS – SHALLOW WELL

HP/Order No.	½ HP – JRS5					¾ HP – JRS7					1 HP – JRS10				
Nozzle	AN018					AN018					AN018				
Venturi	AD3330					AD3336					AD3339				
Total Suction Lift (feet)	Discharge Pressure – PSI					Discharge Pressure – PSI					Discharge Pressure – PSI				
	20	30	40	50	Max. Shut-off (PSI)	30	40	50	Max. Shut-off (PSI)	30	40	50	60	Max. Shut-off (PSI)	
	Gallons per minute					Gallons per minute				Gallons per minute					
5	14.1	13.3	10.5	5.8	64	22.5	17.9	12.4	69	27.0	22.4	15.7	9.6	72	
10	12.4	12.0	9.2	4.2	59	20.3	16.3	11.5	65	24.5	20.5	14.8	7.5	69	
15	10.5	10.0	8.0	2.4	56	17.8	15.3	9.0	63	21.2	19.2	12.6	5.1	66	
20	8.6	8.5	6.6	1.2	53	14.8	13.6	7.3	61	17.6	16.8	11.1	3.3	63	
25	6.7	6.5	5.0	0.6	51	11.5	10.8	5.2	58	13.4	13.0	8.7	–	61	

PERFORMANCE RATINGS – SHALLOW WELL, HIGH PRESSURE

HP/Order No.	½ HP – JRS5H							
Nozzle	AN020							
Venturi	AD3325							
Total Suction Lift (feet)	Discharge Pressure – PSI							
	20	30	40	50	60	70	80	Max. Shut-off (PSI)
	Gallons per minute							
5	6.7	6.4	6.2	5.8	4.2	2.5	0.8	84
10	5.8	5.6	5.3	5.1	3.7	2.0	NA	82
15	4.8	4.7	4.6	4.5	3.3	1.5	NA	79
20	4.0	3.8	3.7	3.6	3.1	1.3	NA	75
25	3.0	2.9	2.9	2.8	2.3	0.8	NA	74



ITT

Residential Water Systems



Goulds Pumps and the ITT Engineered Blocks Symbol are registered trademarks and tradenames of ITT Corporation. Noryl and Lexan are registered trademarks of GE Plastic.

SPECIFICATIONS ARE SUBJECT TO CHANGE WITHOUT NOTICE.

BJRS August, 2007

© 2007 ITT Corporation

Engineered for life