

370-Series Access Riser

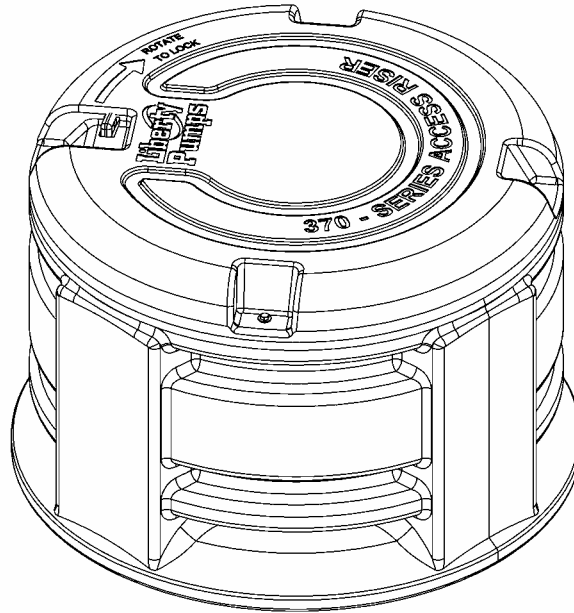

Contents

- 1.) General Information
- 2.) Installation
- 3.) Optional 2" Installation Kits
- 4.) Typical Installation Diagram
- 5.) Junction Box Template

Part Numbers and Descriptions

AR18	Riser only
AC18	Cover only
ARC18	Riser and cover kit
IKIT2-115	2" installation accessories, 115 volt hook-up
IKIT2-230	2" installation accessories, 230 volt hook-up
ARCKIT115	Complete kit ...riser, cover and installation accessories, 115 volt
ARCKIT230	Complete kit ...riser, cover and installation accessories, 230 volt

1. General Information

IMPORTANT: This unit is designed to allow a 370 simplex ejector system to be installed up to 18 inches below grade in an outdoor installation. It fits exclusively the Liberty 370-series system. *It is not a gas or water tight tank extension that increases the capacity of the 370 basin.*

The riser provides a convenient underground chamber for the electrical and pipe connections to exit underground and out-of-sight. A green twist-lock cover can be removed to provide access to plumbing connections, valves and the electrical junction box.

The riser is sold by itself or as a kit with all the necessary components for a professional installation including elbows, electrical fittings and a junction box.

Check with your distributor if you purchased only the riser and would like the optional 2" installation kit.

NOTE: Due to size constraints, only 2" discharge installation kits are available. 3" discharge systems may require that some components be mounted outside of the riser.

2. Installation

- 1) **Install the 370 sewage system per the instructions included with it.** Determine the overall height of the 370 system and riser when excavating and setting the 370 basin. The cover of the access riser should be at ground level when backfilling is complete. Burial depth of the 370 system should not exceed 18" below finished grade. Determine the discharge, electrical, and vent positions relative to the 370 system. The 370 access riser slides over the 370 tank and can be rotated in any direction to simplify plumbing. The riser will rest on the concrete splash lip of the 370 basin.
- 2) **Installation of sidewall pipe seal grommets.** Once exit positions have been determined for both the vent and discharge, a 2" pipe seal grommet can be installed by drilling a 3" hole in the sidewall of the riser. The riser has four flat areas as well as a large ring that runs around the riser to which the discharge pipe or vent can exit. If both a check and ball valve are required, the discharge needs to exit on the opposite side as illustrated on page 4. To ease installation of the pipe through the pipe seal grommet, grease the pipe or use liquid soap as a lubricant.
- 3) **Install the discharge.** A 90° elbow can be threaded onto the discharge pipe of the 370 system. A check valve is recommended to prevent water from back flowing and filling the basin. **NOTE:** In northern climates where frost may be a concern, pipes exiting from the side of the system may be exposed to freezing conditions. If this unit is installed in a frost zone, do not use a check valve. Substitute a union to facilitate 370-cover removal and pump access. If a check valve is not used, the vertical lift should be minimized to reduce the amount of back flow after each cycle. A maximum length of 30' of 2" pipe can be pitched to drain back into the 370 system. Beyond 30', discharge piping should be pitched down towards the final discharge destination. A ball valve is recommended so that back flow can be prevented in the event that the pump or check valve must be removed for service. When connecting the check valve, ball valve, etc. take care to position items as close to the sidewall of the riser as possible to allow room for removal of the 370 cover. Use unions and couplings as necessary to allow for this.
- 4) **Connection of vent.** To maintain hidden pipes, the vent pipe can be routed underground to an existing household vent. For a 2" vent, a 3" hole should be drilled in the sidewall of the riser where the vent pipe is to exit. Install the pipe seal grommet, which is included in the kit. The pipe should be lubricated with liquid soap or grease to ease pipe installation. A 90° elbow with male threads should be threaded into the vent flange of the 370 system. A rubber slip coupler is provided and should be installed in the vent piping as illustrated on page 4 to allow easy removal of the 370 cover and pump if service is required.
- 5) **Connection of electrical.** A NEMA 4X weatherproof pump station junction box (Liberty model JB120 or JB230) is recommended. It can be mounted inside or outside of the access riser. If mounting inside, a template is included in this manual to drill the four mounting holes. If nonmetallic conduit is used it must be mounted in such a fashion as to be at least 18 inches below grade. Consult the National Electrical Code (NEC) and local codes for further information. Additional instructions are included with the JB120 or JB230 box. A qualified electrician should perform all electrical connections.

- 6) **Backfilling.** Use only fine, 1/8" to 3/4" pea gravel or 1/8" to 1/2" washed, crushed stone as backfill around the access riser. Do not use sand or native soil as backfill. Tamp backfill lightly. Avoid running heavy equipment next to the riser. A light layer of topsoil can be used at cover level.
- 7) **Installation of cover.** The cover features a twist-lock design and 4 stainless steel screws to secure it. When installing the cover, line up the four tabs with the four receptacles and locking tongue which fits into a cut recess in the under side of the cover. Push down and rotate the cover in a clockwise direction until the tongue bottoms in the slot. Install the four stainless steel bolts to secure the cover. A padlock can be placed through a hole in the tongue to deter unwanted entry. The cover is designed to handle light traffic loads such as walking or light lawn and garden equipment. **DO NOT RUN HEAVY TRACTORS OR OTHER EQUIPMENT OVER THE COVER. MAXIMUM LOAD RATING IS 250 LBS.**

3. Optional 2” Installation Kits

<u>Kit Number</u>	<u>Description</u>
IKIT2-115	Installation accessories Kit, 2” discharge, 115V wiring box
IKIT2-230	Installation accessories Kit, 2” discharge, 230V wiring box (1-phase)

Liberty risers are sold independently or as a kit with all of the necessary installation accessories. If your riser did not include the installation kit, contact your distributor for pricing and availability or call the factory at 1-800-543-2550. See *Liberty 370-series literature for complete information on installation kits.*

***Installation kits include:**

- Full flow 2” union-type check valve
- PVC Ball Valve
- (2) 90 degree PVC elbows (1 male thread x solvent, 1 female thread x solvent)
- (2) 2” rubber pipe seal grommets
- 2” rubber coupler with clamps
- Model JB120 or JB230 pump station wiring box with:
 - Terminal strip with separate alarm and pump control circuit
 - Receptacle for pump (115 volt or 230 volt depending on model)
 - Riser extension coupling and washers
 - Custom-engineered liquid tight cable seal for pump, switch and alarm cords
 - Electrical conduit hub

**Please note that installation kits do not include Schedule 40 PVC pipe.*

JB120 or 230 Pump Station Wiring Box (NEMA 4X)



4. Typical Installation Diagram

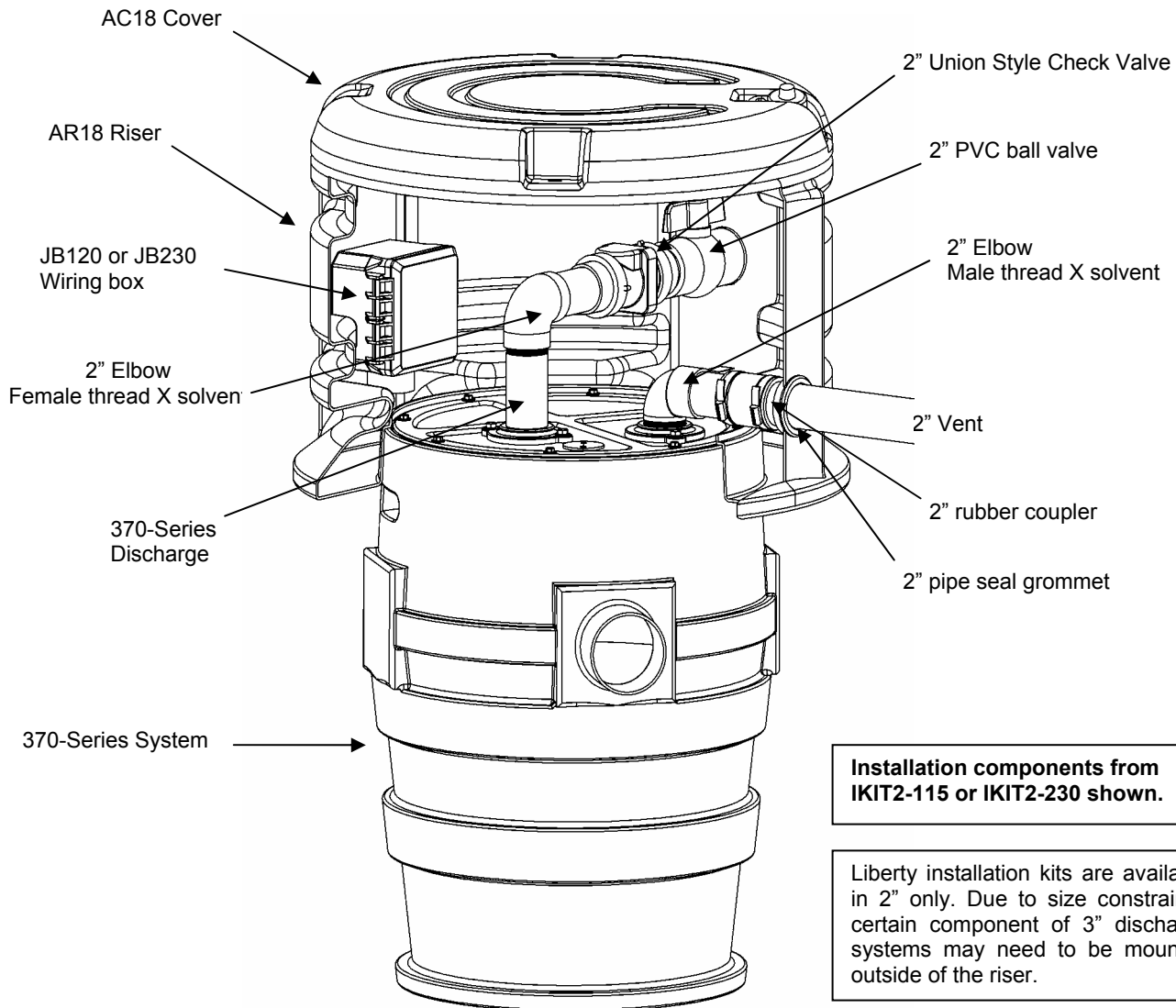

**Installation components from
IKIT2-115 or IKIT2-230 shown.**

Liberty installation kits are available in 2" only. Due to size constraints, certain component of 3" discharge systems may need to be mounted outside of the riser.

2 Year Limited Warranty Liberty Pumps, Inc. warrants that pumps and other products of its manufacture are free from all factory defects in material and workmanship for a period of 2 years from the date of purchase (unless otherwise noted). The date of purchase shall be determined by a dated sales receipt. For pumps, a sales receipt noting the model and serial number of the pump is required. The dated sales receipt must accompany the returned pump if the date of return is more than 2 years from the "CODE" (date of manufacture) number noted on the pump nameplate. The dated sales receipt must also accompany any pump or other product that does not have a "CODE". The manufacturer's obligation under this Warranty shall be limited to the repair or replacement of any parts found by the manufacturer to be defective, provided the part or assembly is returned freight prepaid to the manufacturer or its authorized service center, and provided that none of the following warranty-voiding characteristics are evident: The manufacturer shall not be liable under this Warranty if the product has not been properly installed; if it has been disassembled, modified, abused or tampered with; if the electrical cord has been damaged or improperly spliced; if the pump discharge has been reduced in size; if the pump or other product has been used in hot water or water containing sand, lime, cement, gravel or other abrasives; if the product has been used to pump chemicals or hydrocarbons; if a non-submersible motor has been subjected to excessive moisture; or if the label bearing the serial and code number has been removed. Liberty Pumps, Inc. shall not be liable for any loss, damage or expenses resulting from installation or use of its products, or for consequential damages, including costs of removal, reinstallation or transportation. **There is no other express warranty. All implied warranties, including those of merchantability and fitness for a particular purpose, are limited to two years from the date of purchase.** This Warranty contains the exclusive remedy of the purchaser, and, where permitted, liability for consequential or incidental damages under any and all warranties are excluded.

5. Junction Box Template

