

# Liberty Pumps™

## **NEW!**

# **Pro370-Series**

**with  
QuickTree™  
Technology**

**The most advanced  
residential sewage  
package available**

**Features:**

- **NEW!** separate access cover
- **NEW!** QuickTree™ float system. Allows easy removal of floats without pulling the pump.
- Large 41 gallon capacity
  - Anti-flotation collar
  - Molded torque-stops
- Integrally molded handles
  - Unique integrated cord seal technology
- Integral rubber cover seals

**Shipped with  
Clear Construction Cover**

**NEW!**



**Clear disposable cover protects the system during masonry work and rough-in.**



**2  
YEAR  
WARRANTY**

US Patent #6,305,410  
and Patent Pending

# Pro370

QuickTree™ Technology

## Features:

- NEW! QuickTree™ system allows easy access and removal of switches without disturbing pump or plumbing.
- NEW! Integral rubber seals permanently attached to cover.
- NEW! Unique cord seal technology.
- NEW! Inspection/Access cover.
- Larger basin – 40% more capacity than standard 18" X 30" basins – decreases switch cycles, improves pump life.
- Integrally molded torque stops secure the pump in its proper position.
- Integrally molded anti-flotation collar.
- Integrally molded handles to ease transportation and installation.
- Durable polyethylene construction with radial ribs for added strength.
- Completely assembled.
- Available with any of Liberty's 2" solids-handling sewage pumps.

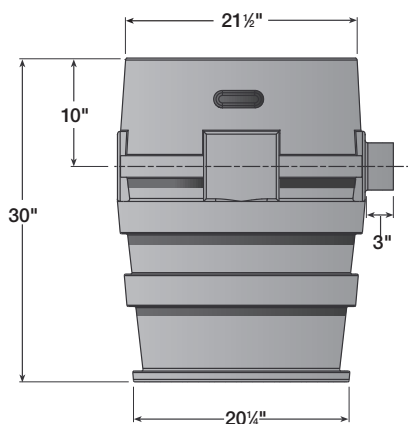

## QuickTree™ Technology

### Integral Rubber Seals

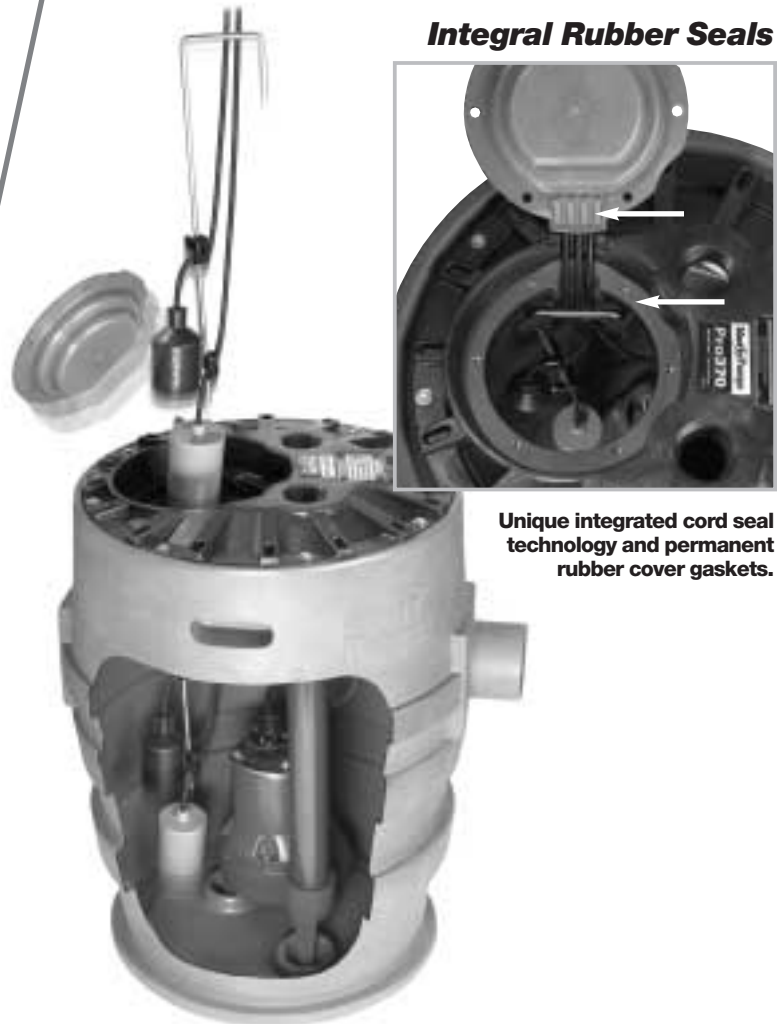

## Specifications: 2" Discharge Systems

MODEL	HP	VOLTS	PHASE	DISCHARGE	WGT. LBS.
P372LE41	4/10	115	1	2"	60
P372LE51	1/2	115	1	2"	64
P372LE52	1/2	208-230	1	2"	63
P372LE71	3/4	115	1	2"	83
P372LE72	3/4	208-230	1	2"	83
P372LE102*	1	208-230	1	2"	86
P372LEH102*	1	208-230	1	2"	86

For 3" discharge systems change model number from "372" to "373."  
EXAMPLE: P373LE41

See specific LE-Series literature for complete pump performance and specifications.  
\* High head applications only. Consult factory for proper pump sizing.

# Pro370-Series 21" x 30" – 41 Gallons

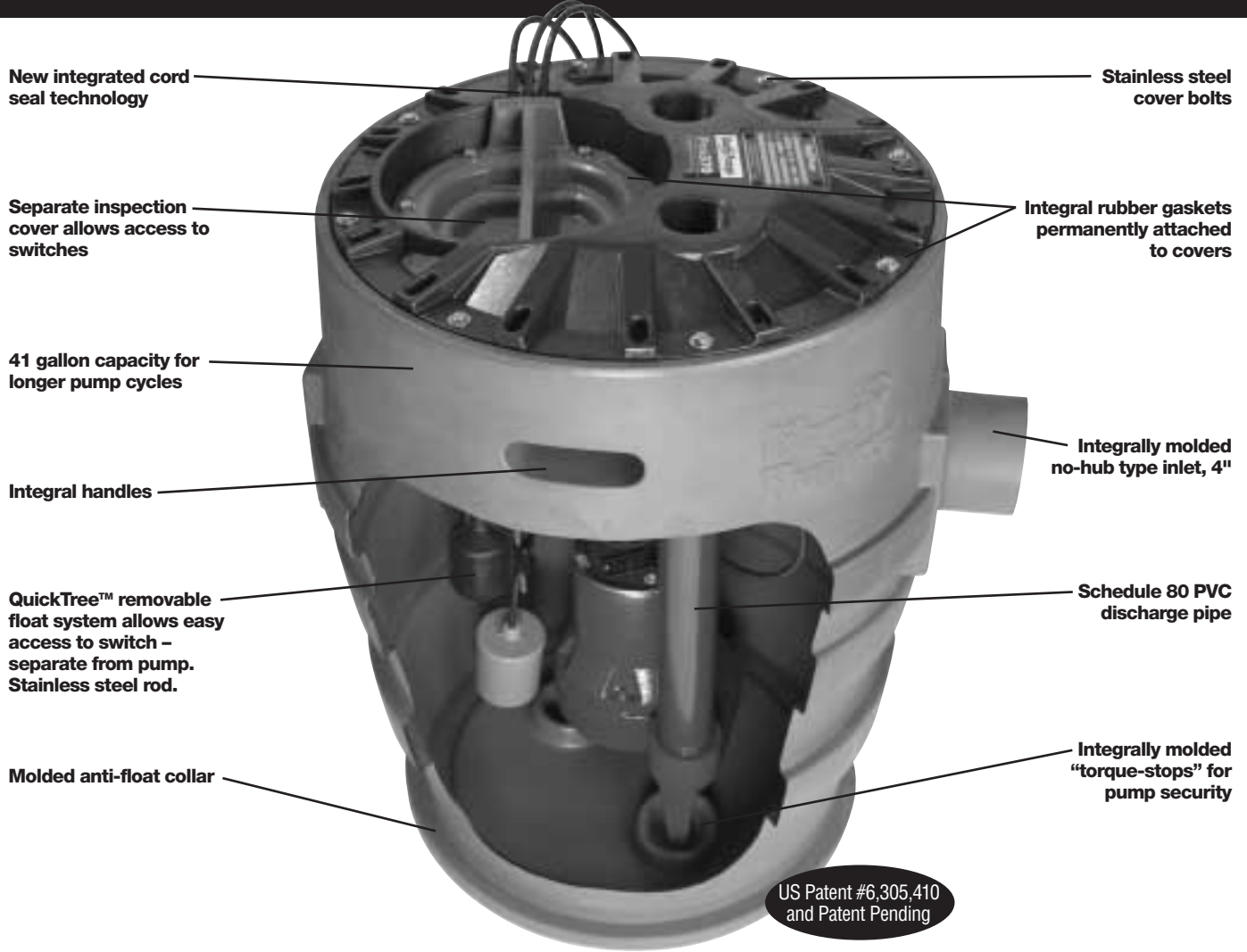

New integrated cord seal technology

Stainless steel cover bolts

Separate inspection cover allows access to switches

Integral rubber gaskets permanently attached to covers

41 gallon capacity for longer pump cycles

Integrally molded no-hub type inlet, 4"

Integral handles

Schedule 80 PVC discharge pipe

QuickTree™ removable float system allows easy access to switch – separate from pump. Stainless steel rod.

Integrally molded "torque-stops" for pump security

Molded anti-float collar

US Patent #6,305,410 and Patent Pending

## New! P370XL Series - IAPMO Listed

The P370XL systems are specifically designed to pass a 10' stack test and are IAPMO listed.

The P370XL-Series has all the same features as the standard P370 except for a 16 bolt cover.

To order, simply add "X" to any standard P370 system.  
**Example: P372XLE41**

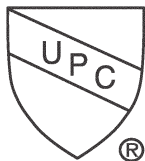

## QuickTree™ Kit

Installed your Pro370 empty? Simply order a QuickTree™ Kit and manual LE-Series pump.



QuickTree™ Kit comes complete with stainless steel rod, pump float and clamps pre-mounted.

Need to install a Liberty pump in an empty Pro370 basin? ...No-Problem! QuickTree™ Kits make addition of a pump easy! Simply install a manual LE-Series pump and a matching QuickTree™ Kit. Kits include stainless steel float tree, pre-mounted pump float and additional clamp for an alarm float. Simply hang the QuickTree™ from its holder underneath the access cover and your ready to go.

MODEL	DESCRIPTION
QT370-115-10	QuickTree for PRO370, 115V, 10' cord
QT370-115-25	QuickTree for PRO370, 115V, 25' cord
QT370-230-10	QuickTree for PRO370, 230V, 10' cord
QT370-230-25	QuickTree for PRO370, 230V, 25' cord

**Riser allows burial of the Pro370 System up to a maximum depth of 18" below grade.**

A convenient chamber for all your pump's electrical and piping connections – out of sight and below grade. Riser simply slides over the sealed 370 system. Cover is retained by 4 stainless steel bolts and features a twist-lock design with provision for padlock to deter unwanted entry.

**Specifications:**

**Weight: 28 lbs.- (Riser and Cover)**

**Riser Height: 18-3/4"**

**Total Height with Cover: 20-1/2"**

**Diameter: 32"**

MODEL	DESCRIPTION
AR18	Access Riser
AC18	Access Riser Cover (Environmental Green)
ARC18	Kit, Access Riser with Cover
ARCKIT115	Kit, Access Riser with Cover and 2" installation accessories - 115V
ARCKIT230	Kit, Access Riser with Cover and 2" installation accessories - 230V
IKIT2-115	Installation Kit 2", 115V
IKIT2-230	Installation Kit 2", 230V

# Optional Access Riser

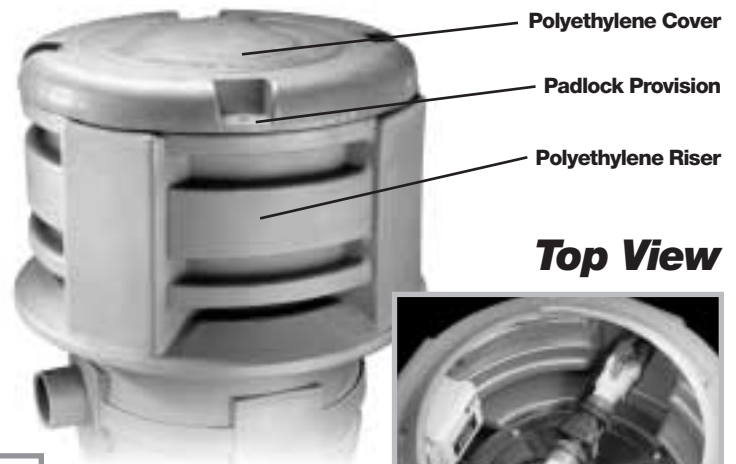

**Top View**



Liberty's installation kits provide all the components for a professional installation inside the riser. Kit includes: JB-Series wiring box and hardware, check valve with a disconnect union feature, coupling and elbows (PVC piping not included). Kits available in 2" discharge and vent size only.

## Pro370-Series Alarmed System



**ALM-2W**  
Outdoor Rated  
115 volt Alarm  
(not shown)

**ALM-2 (pictured)**  
Indoor 115V Alarm  
with 9 volt Battery  
Back-up

Now, have the assurance of early warning in the event of a high-level condition with an alarm option installed from the factory! We do the work for you by mounting the alarm float in the basin at its proper level – no need to even open the cover! Simply mount the alarm panel in its desired location, supply power and connect the alarm float leads! Offered with three different alarm options for indoor or outdoor applications.

**How to Order:**

Alarm Model	Add Suffix	Ordering Example
ALM-2	/A2	P372LE41/A2
ALM-2W	/A2W	P372LE41/A2W

Alarm float is pre-set at proper level in basin.  
Alarm panel packaged with unit.