

Liberty Pumps™

NEW!

SBX-Series



SumpBox™

by Liberty Pumps

With debris filter technology



One or more
Patent Pending

***A professional
groundwater
protection system
for new home
construction***

Features:

- Fully assembled.
- Available with 1/3 or 1/2 hp pumps.
- Unique debris filter tray.
- Large 41 gallon capacity.
- Easy access cover requires no tools to open.
- Easy to service float switches located in holders under access cover.
- Available with pre-set alarm.
- Sealed covers radon-ready.

innovate. evolve.

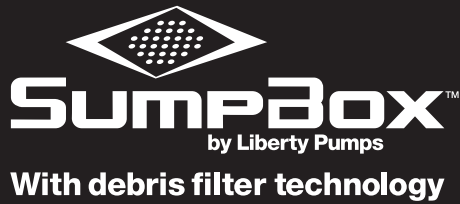

SumpBox™
by Liberty Pumps
With debris filter technology

Performance Curve

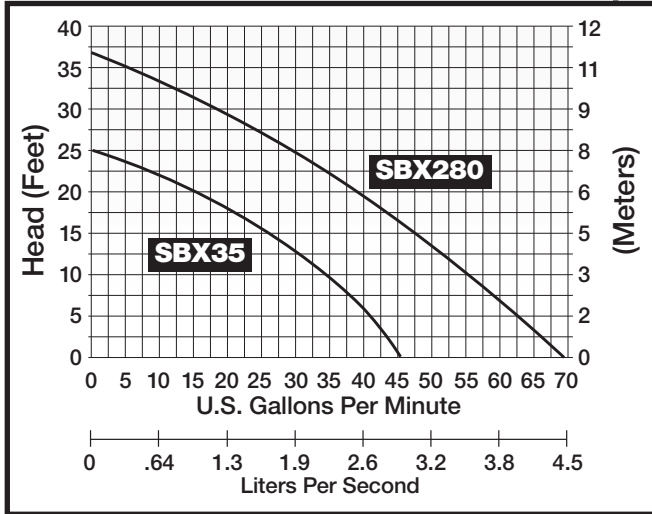

SBX-Series Specifications

Basin Material	Rotationally molded polyethylene
Covers and Filter Tray	Structural Foam
Total basin capacity	41 US Gallons
Capacity per pump cycle	9.3 US Gallons
Filter tray capacity	15 US Quarts
Filter tray flow rates	up to 125 GPM
Straining	3/16"
Height	18-3/4"
Width	24"
Length	32"
Inlets	(3) integrally molded. 4"
Access Cover	Sealed, hand tighten fasteners
Pump Cover	Sealed, bolted stainless fasteners
Discharge	1-1/2" female NPT
Vent	(Optional) 3" grommet seal, uninstalled
Pump options	S35 1/3hp, 115V 280 1/2hp, 115V
Anti-float collar	Yes
Alarm	(Optional) ALM-2 with vertical float
Construction cover	Clear, disposable

Pre-Assembled Systems

Model	Pump	HP	Volts	ALM-2 Alarm	GPM@10'	Maximum (shut-Off) Head	Weight
SBX35-Series							
SBX35	S35	1/3	115V	No	35	25'	50
SBX35A	S35	1/3	115V	Yes	35	25'	50
SBX280-Series High-Output							
SBX280	280	1/2	115V	No	56	37'	67
SBX280A	280	1/2	115V	Yes	56	37'	67

See S35 or 280-Series literature for complete pump specifications.

Dimensional Data

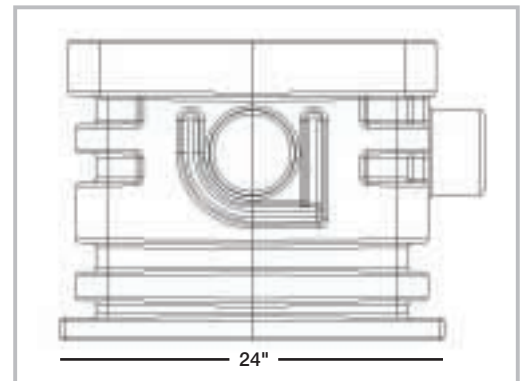
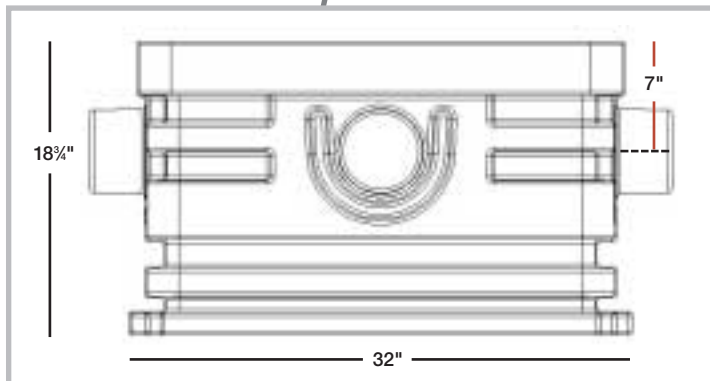

SBX-Series Features

Pre-mounted 1/3 or 1/2 hp pump secured with torque-stops

Easily serviced switches located under access cover

Safety overflow feature

Removable 15 quart filter tray

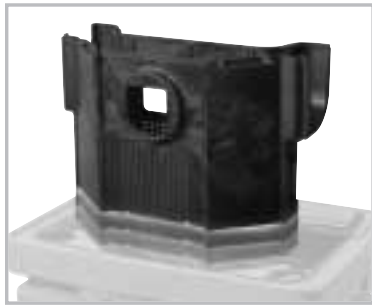

Sealed access cover requires no tools to open

Schedule 80 PVC discharge, 1-1/2" female NPT

Pump cover securely bolted with stainless steel fasteners

Gasket provides a gas-tight seal for radon installations

(3) 4" Inlets

Alarm float (optional)

Anti-float collar with "Staking" locators

Shipped with a Clear Disposable Construction cover!

Protects the system during rough-in and masonry work



Radon-Ready

Provision for 3" Vent Pipe (Pipe seal included, uninstalled)

All Radon installations should be done by a qualified professional and in accordance with applicable codes.

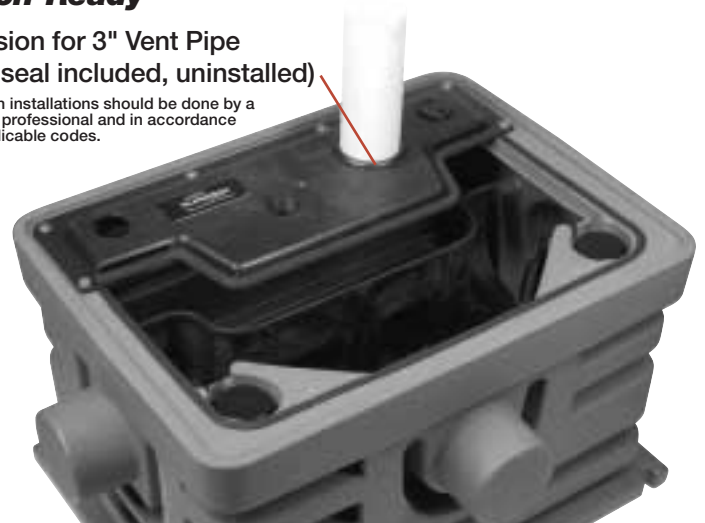

vate. evolve.

Rough-in and Finish Kits

Model – SBX-Rough

Rough-in kit, includes basin, filter tray, covers and clear disposable cover (no pump).

Finish Kits Everything you need to finish off an SBX-Rough. Includes pump, internal pipe and float switch. (ALM-2 alarm and switch included on "A" models.)

Model	Pump model	HP	Volts	GPM@10'	Maximum Head	Alarm Included
FKIT35	S35	1/3	115V	35	25'	No
FKIT35A	S35	1/3	115V	35	25'	Yes
FKIT280	280	1/2	115V	56	37'	No
FKIT280A	280	1/2	115V	56	37'	Yes

SBX-Security Options

FKITALM

Alarm only for SumpBox. Includes ALM-2 alarm and switch pre-set for SumpBox. Alarm features 115 volt operation, 9 volt battery back-up, red alarm light and 86 db horn and low battery chirp.

FKIT441

Model 441 12 volt back-up pump system designed specifically for the SumpBox. Includes pump, piping, check valve, pre-set float switch, battery case, and 4-stage charger. (12 volt marine-grade battery not included.) See model 441 literature for complete specifications. (Note: FKIT441 includes an alarm feature. FKITALM not required when using FKIT441.)

FKIT441
Shown
installed.
Requires
assembly.



WWW.
libertypumps
.COM

Liberty Pumps • 7000 Apple Tree Avenue • Bergen, New York 14416
Phone 800-543-2550 Fax (585) 494-1839

Specifications are subject to change without notice. Copyright © Liberty Pumps, Inc. 2004 All rights reserved. LLIT4000 R06/06