

Liberty Pumps™

NEW!

Pro380-Series

**with
QuickTree™
Technology**

**Larger capacity.
Shallow system
design.**

Features:

- **NEW!** separate access cover
- **NEW!** QuickTree™ float system. Allows easy removal of floats without pulling the pump.
- Shallow 24" basin for easier burial in difficult soil conditions
 - Large 41 gallon capacity
 - Anti-flotation collar
 - Molded torque-stops
 - Integrally molded handles
 - Unique integrated cord seal technology
- Integral rubber cover seals

**Shipped with
Clear Construction Cover**

NEW



Clear disposable cover protects the system during masonry work and rough-in.



**2
YEAR
WARRANTY**

Patent Pending

innovate. evolve.

Pro380

QuickTree™ Technology

Features:

- NEW! QuickTree™ technology allows easy access and removal of switches without disturbing pump or plumbing.
- NEW! Integrated rubber seals permanently attached to cover.
- NEW! Unique cord seal technology integrated into the inspection cover.
- Shallow basin design (24") for easier installation in difficult soil/bedrock locations.
- Large 41 gallon capacity for longer pump cycles.
- Integrally molded torque stops secure the pump in its proper position.
- Integrally molded anti-flotation collar.
- Durable polyethylene construction.
- Completely assembled.

QuickTree™ Technology

Integral Rubber Seals

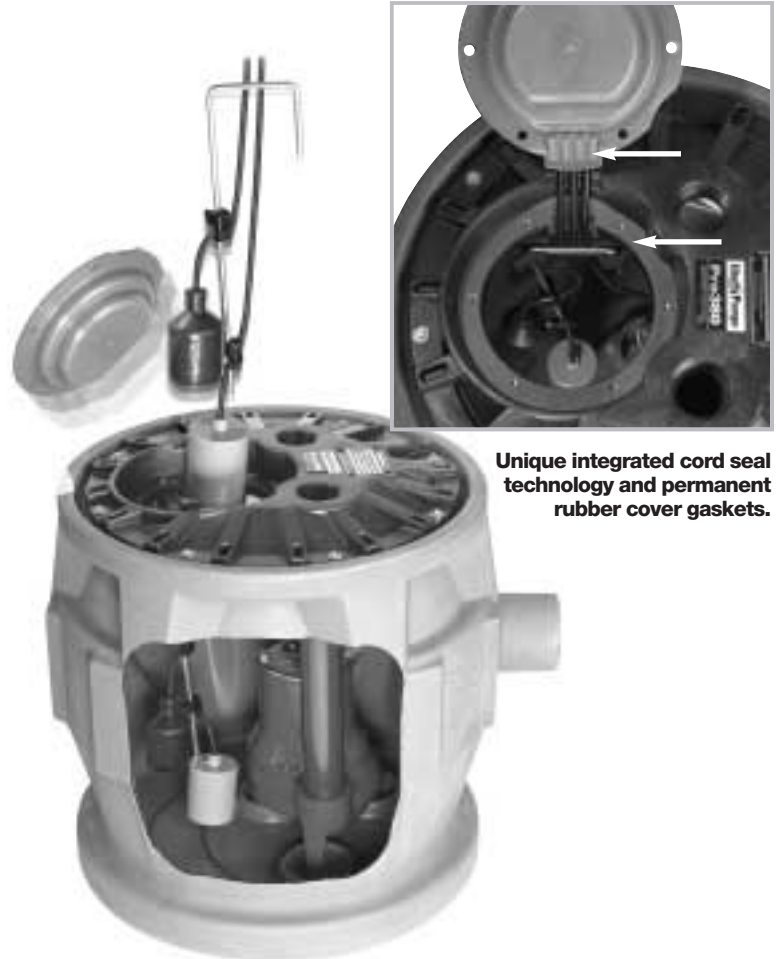

Unique integrated cord seal technology and permanent rubber cover gaskets.

Specifications: 2" Discharge Systems

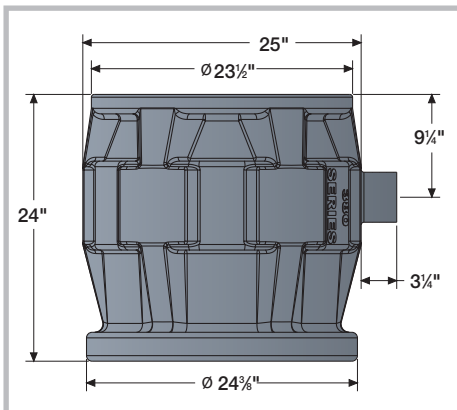

MODEL	HP	VOLTS	PHASE	DISCHARGE	WGT. LBS.
P382LE41	4/10	115	1	2"	60
P382LE51	1/2	115	1	2"	64
P382LE52	1/2	208-230	1	2"	63
P382LE71	3/4	115	1	2"	83
P382LE72	3/4	208-230	1	2"	83
P382LE102*	1	208-230	1	2"	86
P382LEH102*	1	208-230	1	2"	86

For 3" discharge systems change model number from "382" to "383."
EXAMPLE: P383LE41

See specific LE-Series literature for complete pump performance and specifications.
* High head applications only. Consult factory for proper pump sizing.

Pro380-Series 24" x 24" – 41 Gallons

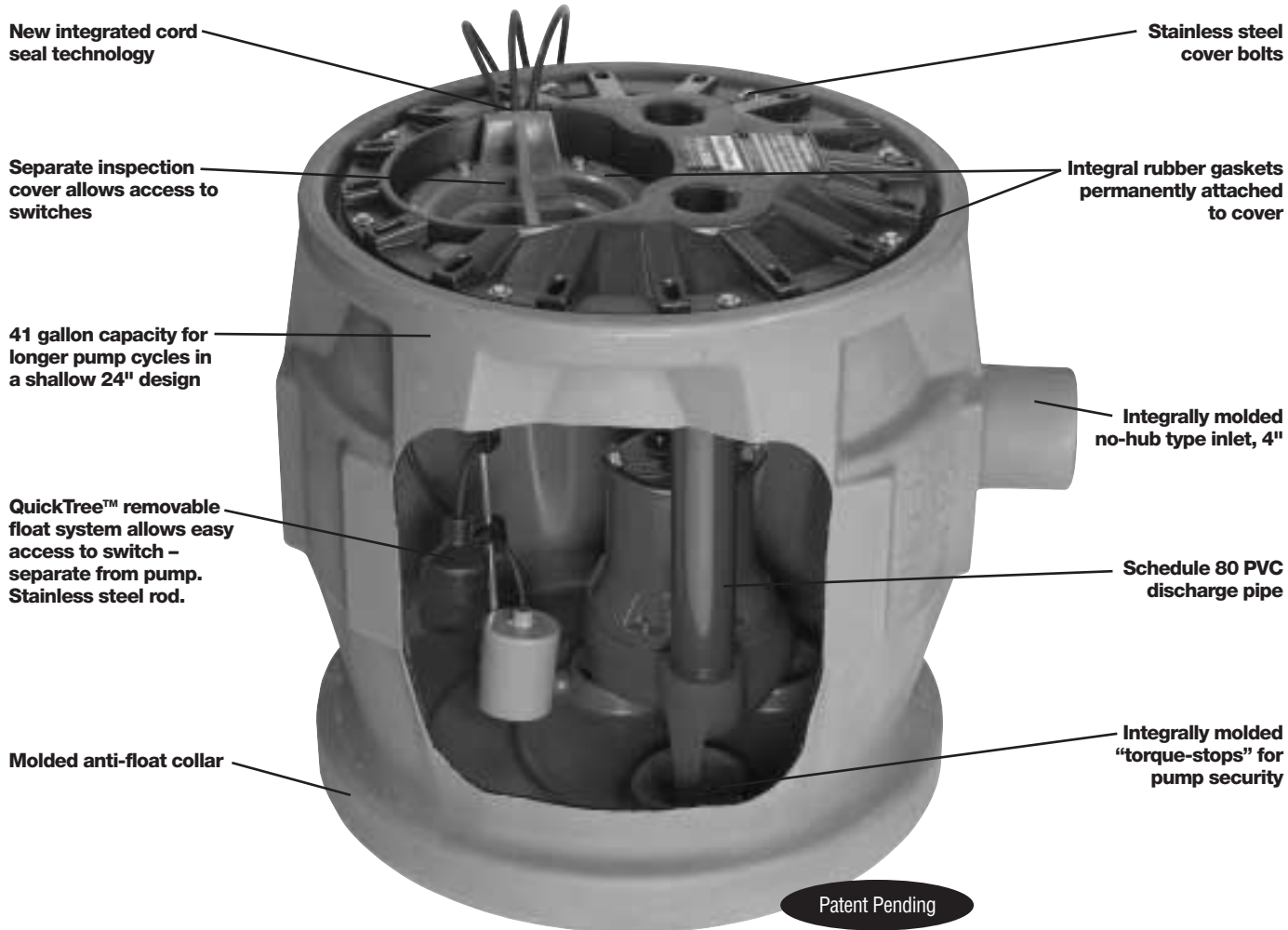

QuickTree™ Kit

**Installed your Pro380 empty?
Simply order a QuickTree™
Kit and manual LE-
Series pump.**



Need to install a Liberty pump in an empty Pro380 basin? ...No-Problem! QuickTree™ Kits make addition of a pump easy! Simply install a manual LE-Series pump and a matching QuickTree™ Kit. Kits include stainless steel float tree, pre-mounted pump float and additional clamp for an alarm float. Simply hang the QuickTree™ from its holder underneath the access cover and your ready to go.

MODEL	DESCRIPTION
QT380-115-10	QuickTree for PRO380, 115V, 10' cord
QT380-115-25	QuickTree for PRO380, 115V, 25' cord
QT380-230-10	QuickTree for PRO380, 230V, 10' cord
QT380-230-25	QuickTree for PRO380, 230V, 25' cord

Pro380-Series Alarmed System



ALM-2W
Outdoor Rated
115 volt Alarm
(not shown)

ALM-2 (pictured)
Indoor 115V Alarm
with 9 volt Battery
Back-up

Now, have the assurance of early warning in the event of a high-level condition with an alarm option installed from the factory! We do the work for you by mounting the alarm float in the basin at its proper level – no need to even open the cover! Simply mount the alarm panel in its desired location, supply power and connect the alarm float leads! Offered with three different alarm options for indoor or outdoor applications.

How to Order:

Alarm Model	Add Suffix	Ordering Example
ALM-2	/A2	P382LE41/A2
ALM-2W	/A2W	P382LE41/A2W

Alarm float is pre-set at proper level in basin.
Alarm panel packaged with unit.

New! P380XL Series - IAPMO Listed

The **P380XL** systems are specifically designed to pass a 10' stack test and are IAPMO listed.

The **P380XL-Series** has all the same features as the standard P380 except for a 16 bolt cover.

To order, simply add "X" to any standard P380 system.

Example:
P382XLE41



Liberty Pumps • 7000 Apple Tree Avenue • Bergen, New York 14416
Phone 800-543-2550 Fax (585) 494-1839

Specifications are subject to change without notice. Copyright © Liberty Pumps, Inc. 2004 All rights reserved. LLIT3800 R09/05