

## WRS-5

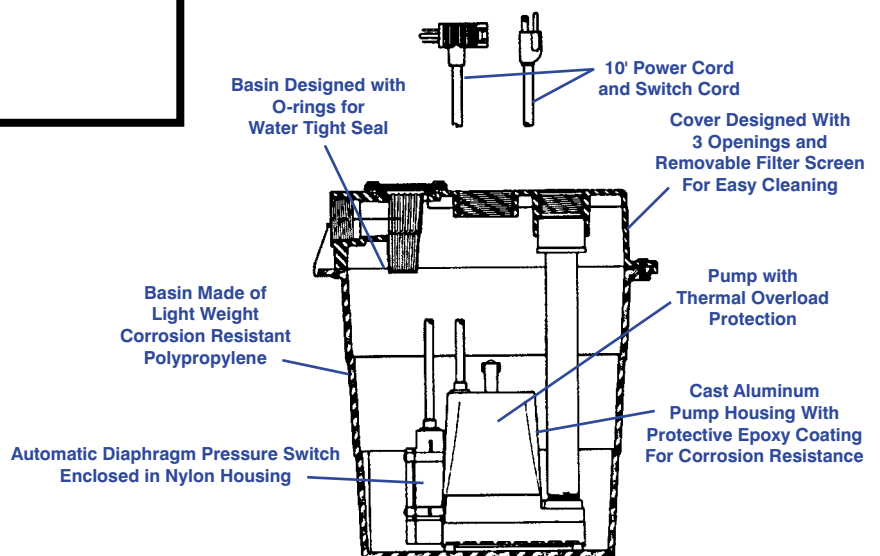

### Features

- Pump made of cast aluminum housing with protective epoxy coating for corrosion resistance
- Screened intake
- 1/6 HP motor with thermal overload protection
- Automatic diaphragm pressure switch enclosed in nylon housing with "on" level at 7"- 10" and "off" level at 1"- 4"
- Basin made of polypropylene — light weight, and corrosion resistant
- Basin designed with o-rings to provided a water tight seal
- Basin cover comes with a removable filter screen for easy cleaning
- Cover comes with 1-1/2" FNPT discharge opening, a 1-1/2" FNPT intake opening and a 2" FNPT vent opening
- IAPMO listed basin
- Pre-Assembled, ready to be installed



The "DRAINOSAUR Jr." removes water from laundry trays, lavatory sinks, wet bar sinks, dehumidifiers, air conditioners (condensate), water softeners, etc. Installs above floor, no need to dig a sump. Unit is pre-assembled and ready to install.

# Little Giant Pump Co.

## WRS-5 WASTE WATER REMOVAL SYSTEM

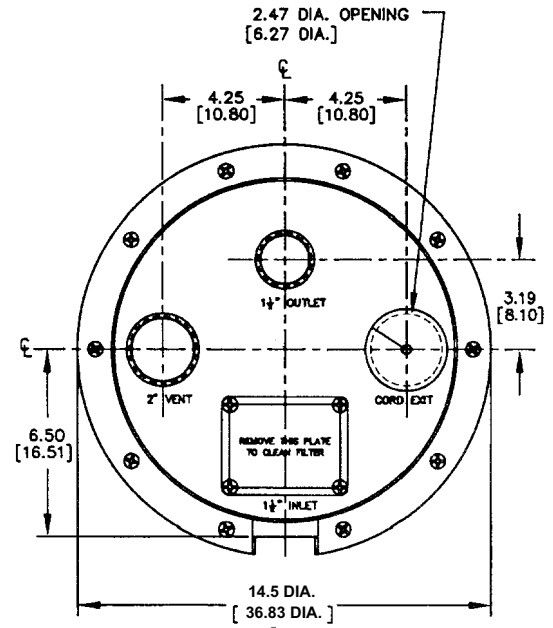
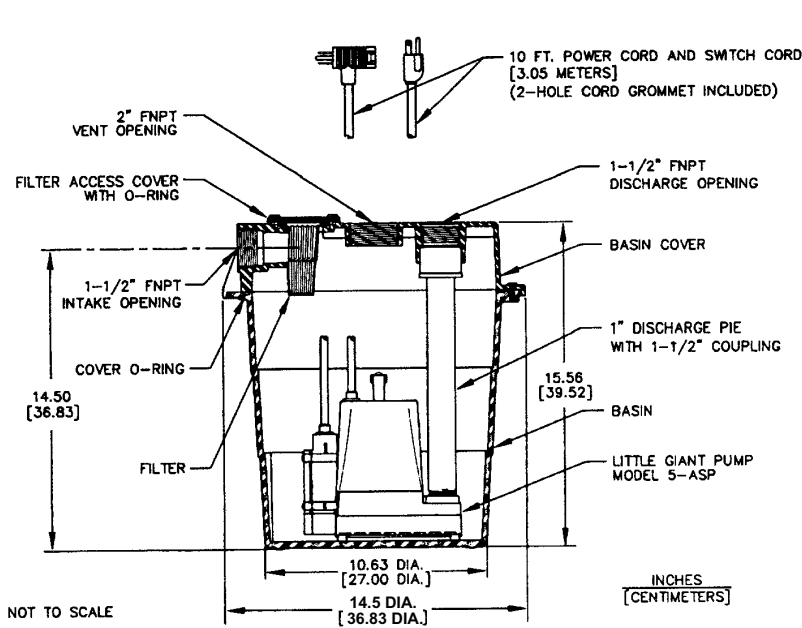

TOP VIEW OF COVER

### Specifications

MODEL NO.	ITEM NO.	DISCHARGE	LISTING	HP	VOLTS	Hz	RUNNING AMPS/WATTS	PERFORMANCE (GPM@HEAD)				WEIGHT	DIMENSIONS (WxH)
								15'	10'	15'	SHUTOFF		
WRS-5	505055	1-1/2"	UL/CSA/IAPMO	1/6	115	60	5/380	15	11	8	21	19 lbs	14.5 x 15.56

UL/CSA Listing for pump only

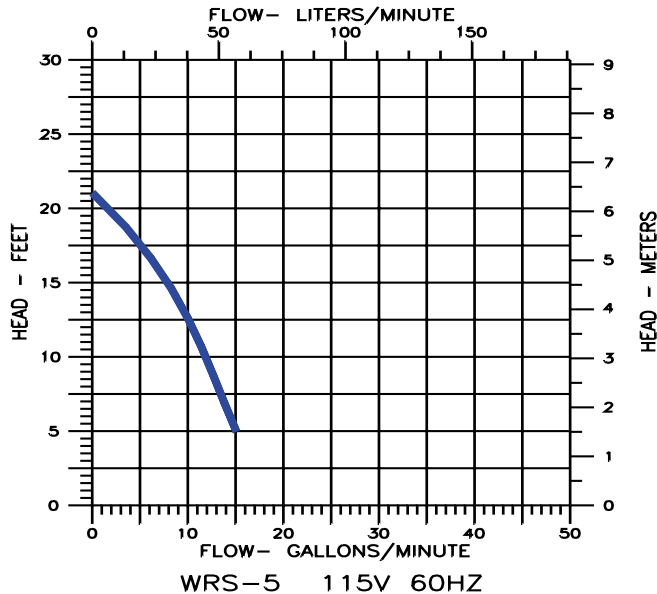

### Pump Construction

MOTOR HOUSING	Epoxy-coated Cast Aluminum
IMPELLER MATERIAL	Nylon
VOLUTE	Nylon
POWER CORD	18/3, SJTW
MECHANICAL SHAFT SEAL	Double lip Viton
FASTENERS	Stainless Steel
SHAFT	Stainless Steel

### Basin Cover/Construction

BASIN/COVER	Polypropylene
BASIN FLUID CAPACITY (APPROX.)	5 gallons
DISCHARGE SIZE	1 1/2" FNPT
INTAKE SIZE	1 1/2" FNPT
VENT SIZE	2" FNPT



ISO 9001 CERTIFIED

### Little Giant Pump Co.

PO Box 12010  
Okla. City, OK 73157

Phone: 405.947.2511  
Fax: 405.951.5674

[www.LittleGiantPump.com](http://www.LittleGiantPump.com)

Form No. 993197 - 05/01