

Little GIANT[®]

1 - ABS



Features

- Permanently lubricated
- Epoxy coated cast aluminum housing
- Automatic, in-pan design
- Integral float-activated mercury switch*
- 1/4" MNPT discharge
- 10' max lift
- 6' power cord

Construction

- Motor — 1/150 HP
- Intermittent Liquid Temp. up to — 120° F
- Intake — N/A
- Discharge — 1/4" MNPT
- Housing — Epoxy coated cast aluminum
- Cover — Epoxy coated cast aluminum
- Volute — Nylon
- Impeller — Nylon
- Shaft Seal — Nitrile
- Screen — Polyethylene

Shallow pan automatic condensate removal pump that features an “on” level in 1” of water and “off” level in 1/2” of water. The pump is permanently lubricated and designed to maximize heat dissipation. This model is ideal for in-pan placement for condensate removal.

***NOTE:** Any product containing mercury must be recycled or disposed according to local, state and federal rules.

1-ABS

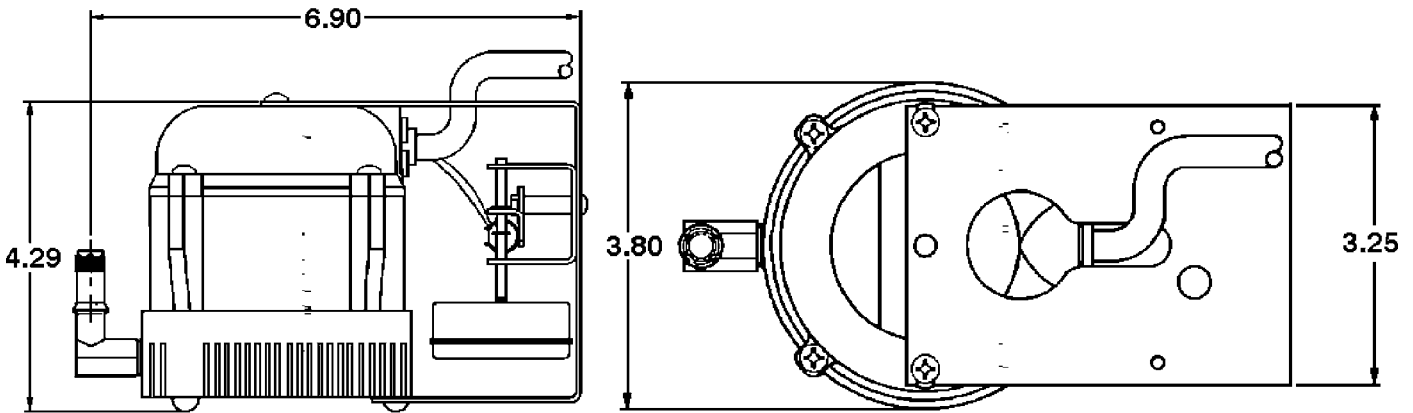

Specifications

Model No.	Item No.	Discharge	Listings	HP	Volts	Hertz	Amps	Watts	Performance (GPH @ Head)				Shut Off		Pwr. Cord (ft.)	Weight (lbs.)
									1'	3'	5'	10'	Feet	PSI		
1-ABS	550515	1/4" MNPT	—	1/150	115	60	1.1	70	205	180	145	0	10	4.3	6	4.33
1-ABS	550525	1/4" MNPT	—	1/150	230	50/60	0.6	70	205	180	145	0	10	4.3	6	4.33

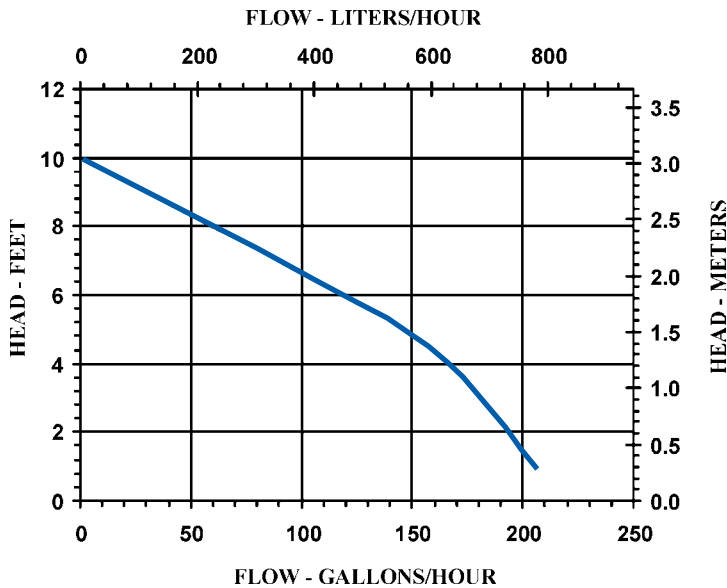

Replacement Parts

Volute	116335
Impeller	116437
Seal Ring	928007
Screen	101901