PE-1F-PW SERIES



Features

- Environmentally safe, oil-less
- Energy efficient
- Corrosion resistant body
- 15' Cord
- 7' maximum lift
- 36 watts
- 1/4" MNPT Discharge
- For submersible use only

Construction

- Motor — 1/125 HP Epoxy Encapsulated
- Intermittent Liquid Temp. up to — 120° F
- Intake — Screened
- Discharge — 1/4" MNPT
- Housing — Polyester
- Cover — Polyester
- Volute — Polypropylene
- Impeller — Polypropylene
- Shaft Seal — Nitrile®
- Screen — Polypropylene

This pump features an epoxy-encapsulated motor, plastic housing and radial lip seal on the motor shaft. It provides enough power to effectively operate a water garden, statuary, or tabletop fountain. Algae build-up does not effect this small, powerful workhorse. In fact, it may even be used in some harsh, industrial-type applications. This "potted" pump is usually more compact in size than an oil-filled pump of equal flow capacity.

Little Giant Pump Co.

PE-1F-PW SERIES

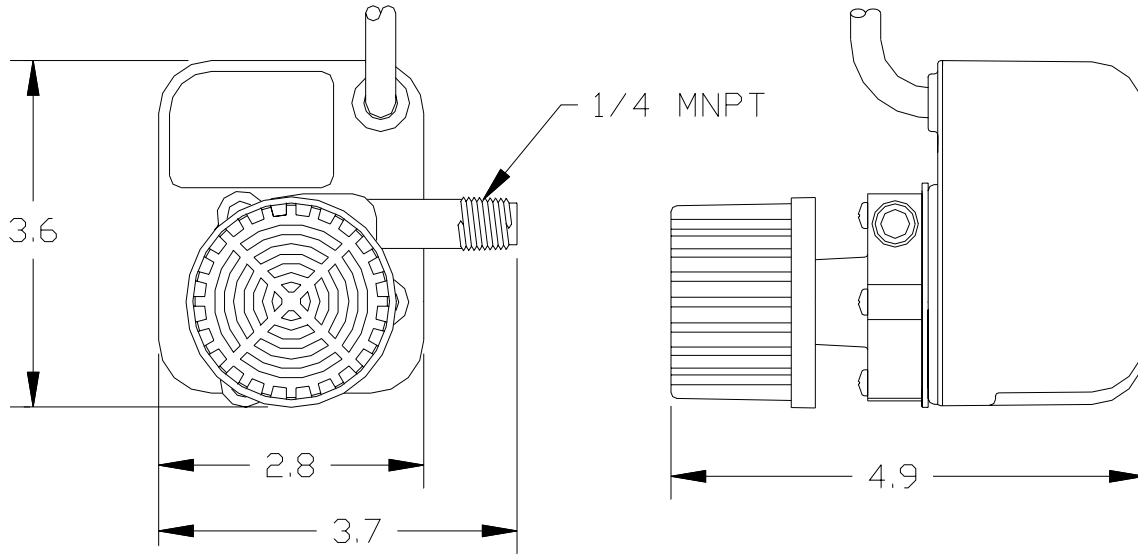

Specifications

Model No.	Item No.	Discharge	Listings	HP	Volts	Hertz	Amps	Watts	Performance (GPH @ Head)					Shut Off Feet	PSI	Pwr. Cord (ft)	Weight (Lbs.)
									1'	2'	3'	4'	5'				
PE-1F-PW	566631	1/4" MNPT	UL/CSA	1/125	115	60	0.6	36	170	160	140	120	100	7	3.0	15	3.67

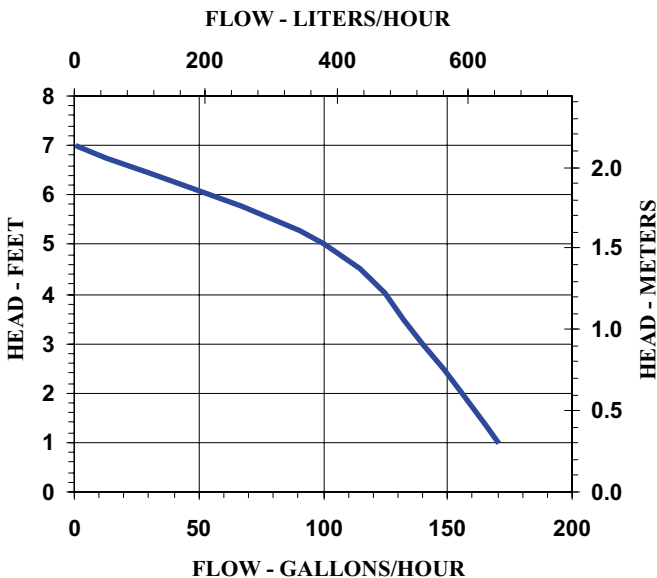

Replacement Parts

Volute	101333
Impeller	118441
Screen	118911
Gasket	101604

Little Giant Pump Co.
 PO Box 12010
 Okla. City, OK 73157
 Phone: 405.947.2511
 Fax: 405.228.1550
www.LittleGiantPump.com